



DISPENSERS PIUSI PITSTOP DC

EN. Dispenser unit with automatic hose reel; 14 metres of hose with automatic nozzle allow dispensing up to 45 l/min with DC power supply.

The automatic hose reel, the two DC pumps and the automatic nozzle are integrated in a sturdy supporting structure. Easy to install, versatile, compact, necessary to complete mobile or fixed tanks.

PIUSI PITSTOP DC consists of:

- 1 - Automatic hose reel.
- 2 - Side safety guards.
- 3 - Adjustable arms with end-of-travel hose stop.
- 4 - Diesel hose 3/4"-14 m (1" - 10 m).
- 5 - On/Off switch.
- 6 - Swivel.
- 7 - Automatic nozzle.
- 8 - DC pumps.
- 9 - Sturdy metal supporting structure.
- 10 - PIUSI filter of the water absorption cartridge type.

On request: fitting of PIUSI K24, digital turbine meter

Available in 80 l/min version with 10 metres of hose.

ES. Grupo de suministro con enrollador automático; 14 metros de tubo con pistola automática permiten suministrar hasta 45 l/min de caudal con alimentación de corriente continua.

El enrollador automático, las dos bombas CC y la pistola automática están integrados en una estructura robusta de soporte. Fácil de instalar, versátil, compacto y necesario para completar depósitos móviles o fijos.

PIUSI PITSTOP CC está compuesto por:

- 1- Enrollador automático
- 2 - Protecciones laterales de seguridad.
- 3 - Brazos regulables con dispositivo sujeta tubo de fin de carrera.
- 4 - Tubo para gasóleo 3/4"-14 m (1" - 10 m).
- 5 - Interruptor de On/Off.
- 6 - Swivel.
- 7 - Pistola automática.
- 8 - Bombas CC.
- 9 - Estructura robusta metálica de soporte.
- 10 - Filtro PIUSI del tipo con cartucho de absorción del agua.

Bajo petición: aplicación del PIUSI K24, cuentalítros digital con turbina

Existe en la versión de 80 l/min con 10 metros de tubo.

PT. Grupo distribuidor com enrolador automático; 14 metros de tubo com pistola automática, permitindo distribuir até 45 l/min de caudal com alimentação de corrente contínua.

O enrolador automático, as duas bombas DC e a pistola automática estão integrados numa robusta estrutura de suporte. Fácil de instalar, versátil, compacto, necessário para completar depósitos móveis ou fixos.

O PIUSI PITSTOP DC é composto por:

- 1 - Enrolador automático.
- 2 - Protecções laterais de segurança.
- 3 - Braços reguláveis com bloqueador de tubos de fim de curso.
- 4 - Tubo para gasóleo 3/4"-14 m (1" - 10 m).
- 5 - Interruptor On/Off.
- 6 - Articulação.
- 7 - Pistola automática.
- 8 - Bombas DC.
- 9 - Robusta estrutura de suporte em metal.
- 10 - Filtro PIUSI do tipo com cartucho de absorção de água.

A pedido: aplicação do PIUSI K24, contador de litros digital com turbina

Disponível na versão de 80 l/min com 10 metros de tubo.

READY TO INSTALL

DIMENSIONS

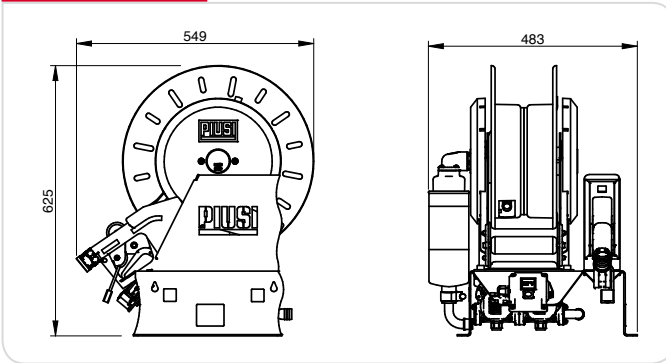

PRODUCTS' RANGE WEIGHT AND PACKAGING

Code	Weight		Packaging		
	kg	lbs	mm	inch	pcs/box
F00212000	45	99	595x465x670	23,4x13,5x24,4	1
F00213000	45	99	595x465x670	23,4x13,5x24,4	1



Flow-rate
up to
45 l/min
(up to 15 gpm)

Hose
14 m

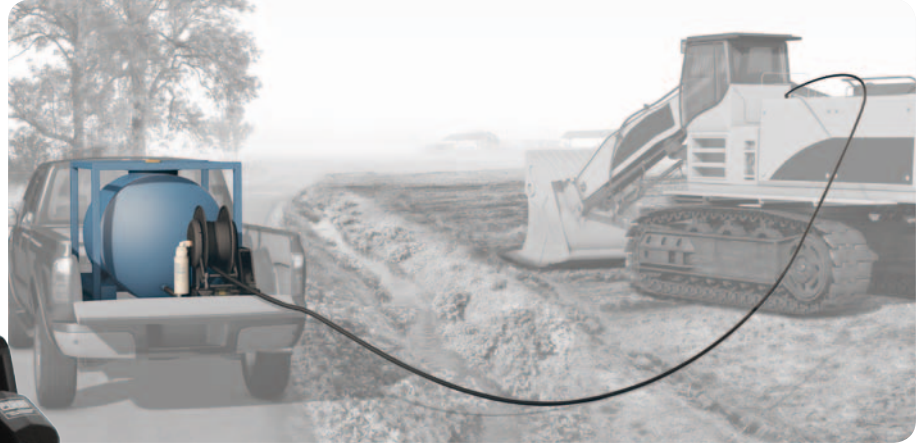

14 m hose



Built in DC pumps



Automatic nozzle

PIUSI PITSTOP DC FUEL TRANSFER SYSTEM

FEATURES



3/4"-14 m (1" - 10 m)



with end-of-travel hose stop.



ON REQUEST

PRODUCTS' RANGE TECHNICAL DATA

Code	Description	Fluids	Flow-rate		Voltage			Pump		Duty cycle	Nozzle	Hose		Inlet	
		type	l/min	gpm	AC V./Hz	Power Watt	Amp. max.	mod.	no.	min.	type	length	Ø	Ø	
F00212000	PIUSI PITSTOP DC 12V	D	45	18	12	400	33	BP 3000	2	30	Aut.	14 m	3/4"	1"	
F00213000	PIUSI PITSTOP DC 24V	D	45	18	24	620	26	BP 3000	2	30	Aut.	14 m	3/4"	1"	