



# DISPENSERS PIUSIBOX

**EN.** Quite often the hard environmental conditions can potentially threaten the re-fuelling operation o OTR equipment and vehicles.  
PIUSIBOX project is the answer to the need of re-fuelling quickly and safety in almost place.

**An important support for the reliability and long last life of your equipments.**

Technical specifications:  
A powerful and reliable self-priming transfer pump capable of delivering 45 l/min, complete with cables and switch.  
Delivery hose and pump nozzle.  
Suction hose with foot valve.

**ES.** *Muy a menudo las condiciones del medio ambiente afectan el reabastecer con gasóleo maquinarias o vehículo. El propósito directo de PIUSIBOX es tener la respuesta a esta necesidad, proveyendo reabastecimiento rápidamente en casi cualquier lugar y con seguridad.*

**Un soporte importante para la larga vida y fiabilidad de su maquinaria.**

Características técnicas:  
*Potente y fiable bomba de trasiego autocebante capaz de suministrar 45 l/min, dotada de cables e interruptor.  
Tubo de impulsión con pistola de suministro  
Tubo de aspiración con válvula de pie*

**PT.** Patentes internacionais que estão em curso de registo Com frequência, as condições ambientais adversas podem comprometer potencialmente a operação de reabastecimento das máquinas de terraplenagem e equipamentos. O projecto PIUSIBOX nasce da exigência de efectuar um reabastecimento rápido e seguro em qualquer lugar.

**Um suporte importante para garantir a confiabilidade e a longa duração de seus equipamentos.**

Especificações técnicas:  
Uma bomba potente e confiável de descarga autodisparadora capaz de distribuir 45 l/min, completa com cabos e interruptor.  
Tubo flexível de débito e pistola  
Tubo flexível de aspiração com válvula de fundo

## PERFORMANCE

- Flow rate up to 45 l/min
- 12-24 V DC operation
- Duty cycle 30 min.

- Caudal hasta 45 l/min
- Funcionamiento 12-24 V CC
- Ciclo de funcionamiento 30 min.

- Caudal até 45 l/min
- Funcionamento 12-24 V DC
- Ciclo de trabalho 30 min

## DIMENSIONS

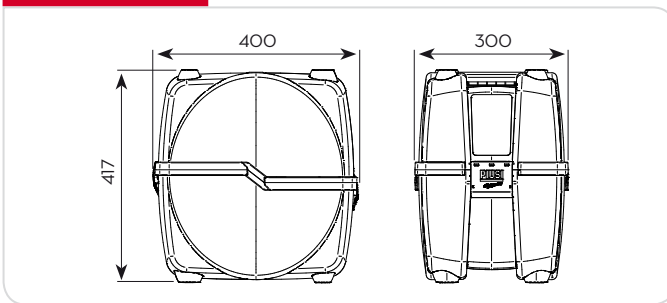

REGISTERED DESIGN

PATENT PENDING

## PRODUCTS' RANGE WEIGHT AND PACKAGING

Code	Weight		Packaging		
	kg	lbs	mm	inch	pcs/box
F0023100A	9,5	20,9	400x300x420	15,7x11,8x16,5	1
F0023101A	12	26,5	400x300x420	15,7x11,8x16,5	1
F0023200A	9,5	20,9	400x300x420	15,7x11,8x16,5	1
F0023201A	12	26,5	400x300x420	15,7x11,8x16,5	1



**Flow-rate**

up to  
**45** l/min  
(up to 11,9 gpm)



DISPENSERS

PUMPS

METERS

NOZZLE METERS

NOZZLE

SPECIAL EQUIPMENTS

FLUID MONITORING

ACCESSORIES

FILTERING



PIUSIBOX PRO



**ON REQUEST**

**K24 KIT (optional)**

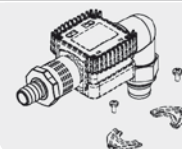

Code R17256000  
Assembly Kit for K24  
PiusiBox

**Cartridge (only Piusi Pro)**



Code F16483010  
15 pcs / box

**FEATURES**

**Flexible hose included**



4 m (PIUSI BASIC)  
6 m (PIUSI PRO)

**Filter + cartridge (only Piusi Pro)**



**On/Off switch included**



**Foot valve included**



Vantage model

**Gloves (only PIUSI PRO)**



**PRODUCTS' RANGE TECHNICAL DATA**

Code	Description	Fluids		Flow-rate		Voltage			Pump mod.	Duty cycle min.	Filter	Cartridge	Nozzle type	Flexible hose lenght	Foot valve mod. Vantage	Gloves
		type		l/min	gpm	AC V/Hz	DC Volt	Power Watt								
F0023100A	PIUSIBOX 12V BASIC	D		45	11,9	12	260	22	BP 3000	30	NO	NO	Man.	4 m.	YES	NO
F0023101A	PIUSIBOX 12V PRO	D		43	11,7	12	260	22	BP 3000	30	YES	10 µm	Man.	6 m	YES	YES
F0023200A	PIUSIBOX 24V BASIC	D		45	11,9	24	310	13	BP 3000	30	NO	NO	Man.	4 m	YES	NO
F0023201A	PIUSIBOX 24V PRO	D		43	11,7	24	310	13	BP 3000	30	YES	10 µm	Man.	6 m	YES	YES

Upon request it is available with different tension and 60 Hz frequency